

**1542R****1542RA**

- 1542R** Traversa idraulica a pantografo pompa manuale  
 Traverse hydraulique à ciseaux avec pompe manuelle  
 Hydraulic jacking beam with manual pump  
 Hydraulischer Scherenheber mit Handpumpe
- 1542RA** Traversa idraulica a pantografo pompa pneumatica  
 Traverse hydraulique à ciseaux avec pompe pneumatique  
 Hydraulic jacking beam with pneumatic pump  
 Hydraulischer Scherenheber mit pneumatischer Pumpe

- Comando discesa ad "uomo presente"
- Bracci telescopici
- Sicurezza idraulica in caso di sovraccarico
- Sicurezza idraulica in caso di rottura dei tubi
- Tamponi in gomma registrabili
- Stelo cromato
- "Dead man" controls
- Telescopic arms
- Safety-valve against overloading
- Safety-valve accidental breakage of feeling pipes
- Rubber blocks
- Chrom-plated rod

- Commande type "homme mort"
- Bras télescopiques
- Sécurité hydraulique en cas de surcharge
- Sécurité hydraulique en cas de rupture de tuyauterie
- Tampons en caoutchouc
- Tige chromée
- Totmannknopf-Betätigung
- Teleskoparme
- UL-Sicherheitsventil
- SB-Sicherheitsventil
- Gummiklötze
- Verchromte Pratze

**OPTIONALS**

**V1542.2** H=85+115mm N° 2 pz.

**V1542.1** H=60mm N° 2 pz.  
**V1542.6** H=100mm N° 2 pz.

**V1542.3 PAD** H=35 120x80mm N° 2 pz.  
**V1542.4 PAD** H=50 120x80mm N° 2 pz.  
**V1542.5 PAD** H=80 160x120mm N° 2 pz.

La ditta si riserva la facoltà di apportare modifiche alle proprie macchine in qualsiasi momento e senza preavviso.  
 Notre Maison se réserve d'apporter des modifications aux machines n'importe sans quand préavis.  
 The manufacturing Company reserves the right to make modifications to its machines at any time without notice.  
 Der Erzeuger behält sich das Recht vor, jederzeit und ohne Vorankündigungen, Veränderungen an den eigenen Geräten durchzuführen.



DATI TECNICI	DONNES TECHNIQUES	TECHNICAL DATES	TECHNISCHE DATEN		1542R 1542RA
Portata	Capacità	Capacity	Tragfähigkeit	kg	3000
Spostamento verticale del carico	Déplacement vertical de la charge	Lifting displacement	Hubhöhe	mm	435
Estensione min. (bracci chiusi)	Extension min (bras fermés)	Min. extension (arms retracted)	Min. Aufnahmebreite arme voll eingefahren	mm	935
Estensione max (bracci aperti)	Extension max (bras ouverts)	Max Extension (arms extracted)	Max Aufnahmebreite arme voll ausgefahren	mm	1725
Passo delle ruote di scorrimento min.	Ecartement der roues de écoulement min.	Wheel base min.	Achsabstand der Laufrollen min	mm	755÷860
Passo delle ruote di scorrimento max.	Ecartement der roues de écoulement max.	Wheel base max.	Achsabstand der Laufrollen max	mm	1105÷1200
Peso della traversa	Poids	Weight	Gewicht	kg	150
Temperatura di funzionamento	Température d'opération	Operative temperature	Betriebstemperatur	°C	-10 +40

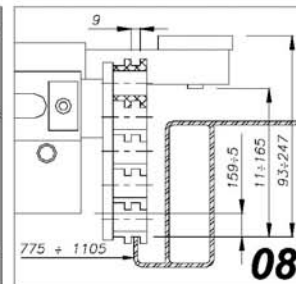
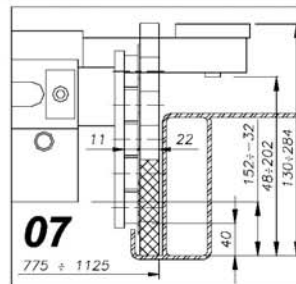
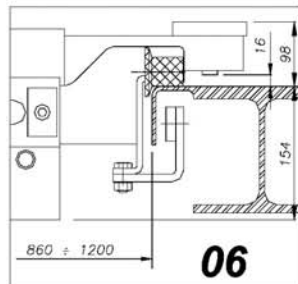
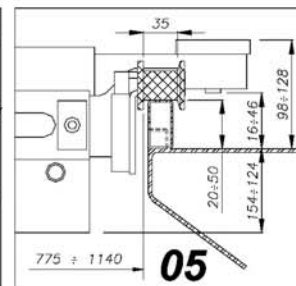
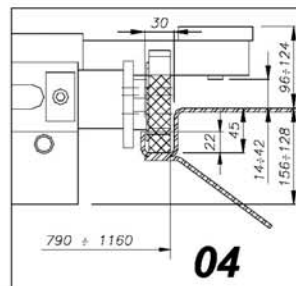
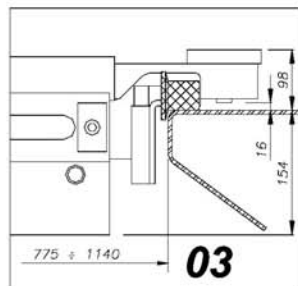
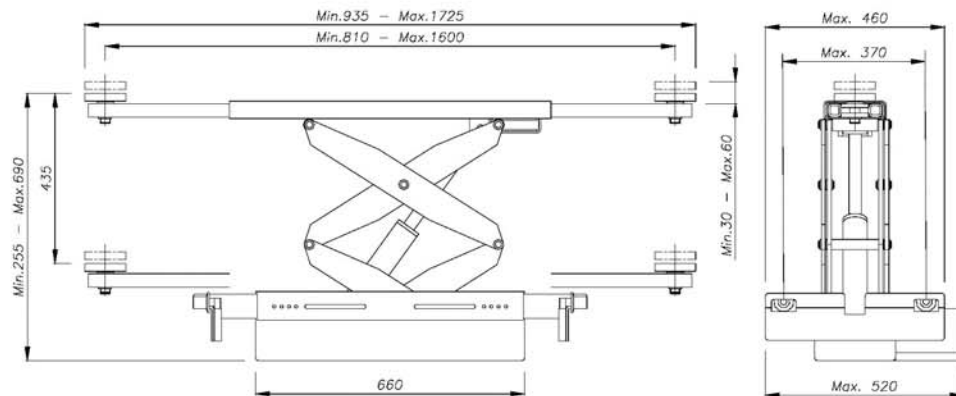

Rullo/Galet/Roller/Rolle

Sollevatore/Pont élévateur/Lift/Säulen

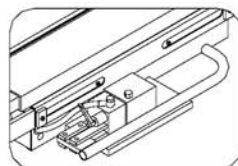

Pompa manuale/Pompe manuelle  
Manual pump/Handpumpe

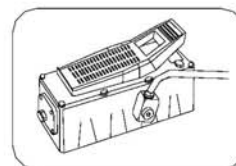

Pompa pneumatica/Pompe pneumatique  
Pneumatic pump/Pneumatischer Pumpe

La ditta si riserva la facoltà di apportare modifiche alle proprie macchine in qualsiasi momento e senza preavviso.  
Notre Maison se réserve d'apporter des modifications aux machines n'importe sans quand préavis.  
The manufacturing Company reserves the right to make modifications to its machines at any time without notice.  
Der Erzeuger behält sich das Recht vor, jederzeit und ohne Vorankündigungen, Veränderungen an den eigenen Geräten durchzuführen.