



**SMONTAGOMME SEMIAUTOMATICO**  
**SWING-ARM TYRE CHANGER**  
**DEMONTE-PNEUS SEMI-AUTOMATIQUE**



**S 112 F**



**DATI  
TECNICI****STANDARD  
FEATURES****DONNEES  
TECHNIQUES****TECHNISCHE  
ANGABEN****DATOS  
TÉCNICOS****S 112 F**

Bloccaggio cerchio	Rim clamping	Blocage jante	Felgeneinspannung	Bloqueo llanta	10" - 20"
Diametro max.ruota	Max.wheel diameter	Diamètre maxi.roue	Max.Raddurchmesser	Diámetro máx. rueda	1000 mm (39")
Largh. max. ruota	Max.wheel width	Largeur maxi.roue	Max.Radbreite	Ancho máx. rueda	330 mm (13")
Forza max. cilindro stallonatore	Max. Bead-loosener cylinder force	Force vérin décolleur maxi.	Max. Kraft des Wulstabdruckzylinders	Fuerza máx. cilindro destalonador	2500 kg
Pressione d'esercizio	Operating pressure	Pression de service	Betriebsdruck	Presión de trabajo	10 bar (145 psi)
Alimentazione	Power supply	Alimentation	Stromzufuhr	Alimentación	230/400 V 3ph
Potenza motore	Motor power	Puissance moteur	Motorleistung	Potencia motor	0,55 kW
Coppia max. mandrino	Max. spindle torque	Couple maxi. mandrin	Maximales Kräftepaar an der Hauptspindel	Par máx. de mandril	1200 Nm
Limitatore pressione gonfiaggio max.	Inflating pressure limiting device max.	Dispositif limiteur de pression de gonflage maxi.	Vorrichtung zur Reifenfülldruckbegrenzung max.	Dispositivo limitador de presión de inflado máx.	3,5 bar (50 psi)
Peso netto	Net weight	Poids net	Nettogewicht	Peso neto	195 kg 5TD 213 kg 6T

The specifications stated on this brochure are not binding, Giuliano s.r.l. reserves the right to change any specification without notice.

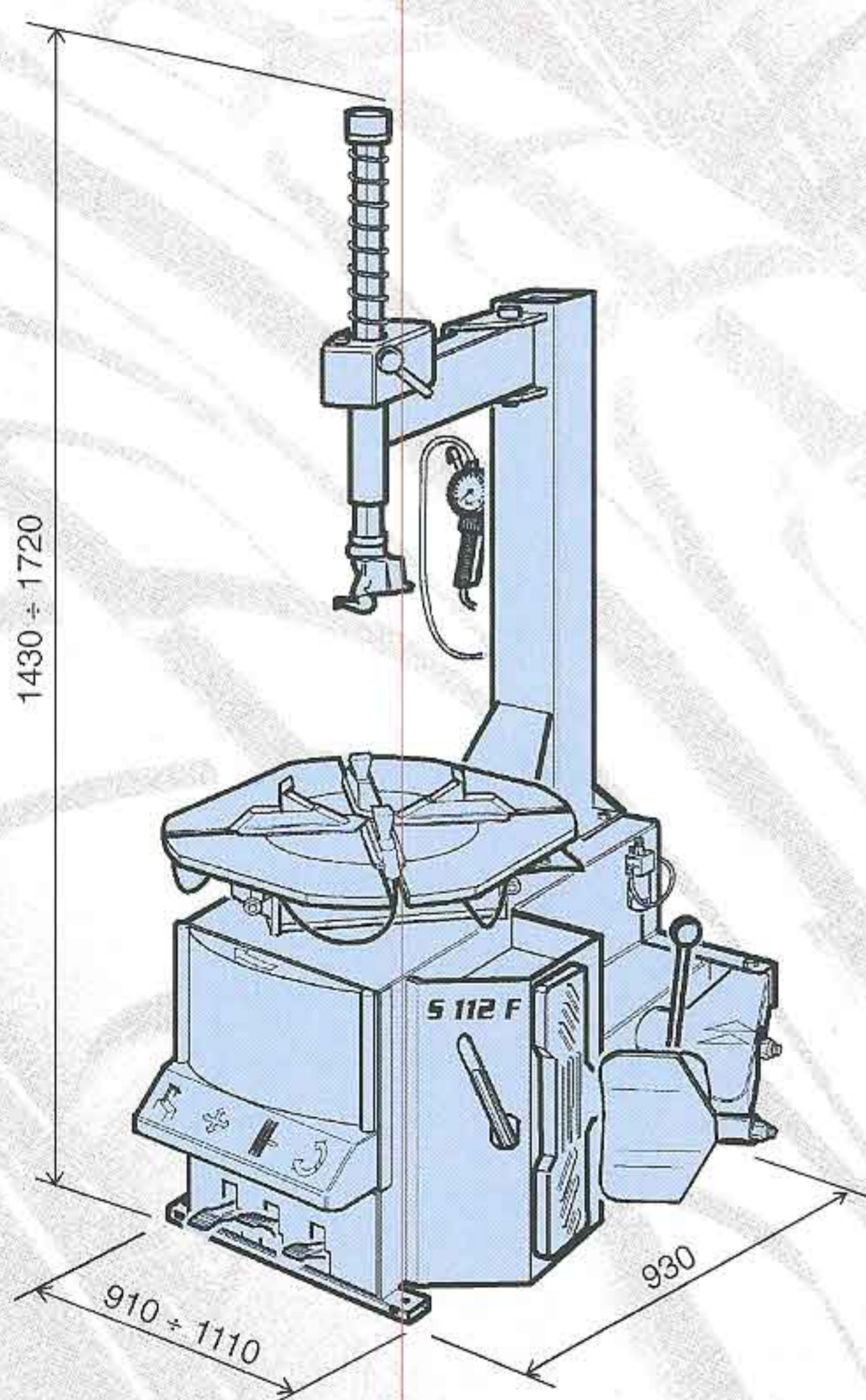
**STANDARD ACCESSORIES****S 112 F**

TYRE-CHANGERS



WHEEL-BALANCERS



LIFTS



BIKE-LINE



TESTING EQUIPMENT



GIULIANO s.r.l. :Via Guerrieri, 6 - 42015 CORREGGIO (RE) ITALY  
Tel. +39 0522 731111 - Telefax +39 0522 633109 - E-mail: giuliano@giuliano.it - Internet :www.giuliano.it

3/2004



CIEVI AGENZIA di PUBBLICITÀ - Reggio Emilia