

ProClamp PLUS

Series 918

Wheel Alignment Clamp



Operating Instructions Product Overview

GEB 001 062

GB

General Information

The **HAWEKA** Wheel Alignment Clamp ProClamp PLUS is a user-friendly clamp and can be mounted easily on almost all kind of rims and wheel alignment machines.

The ProClamp PLUS is used to mount the measuring head of a wheel alignment system on a vehicle's rim.

The clamping range of the wheel alignment clamp for passenger car rims is **12 to 24 inches**.

Please note that the wheel alignment clamp is part of a precision measurement instrument and must be constantly used and stored with great care. This of course also applies to the accessories.

The accessories are also precision tools which must not be used in any other way.

Issue: April 2007

These operating instructions are subject to technical alteration.

1. revised version ProClampPLUS
Illustrations: HAWEKA AG / 30938 Burgwedel

This publication may not be reproduced in any form or by any means.

1. The Wheel Alignment Clamp ProClamp PLUS

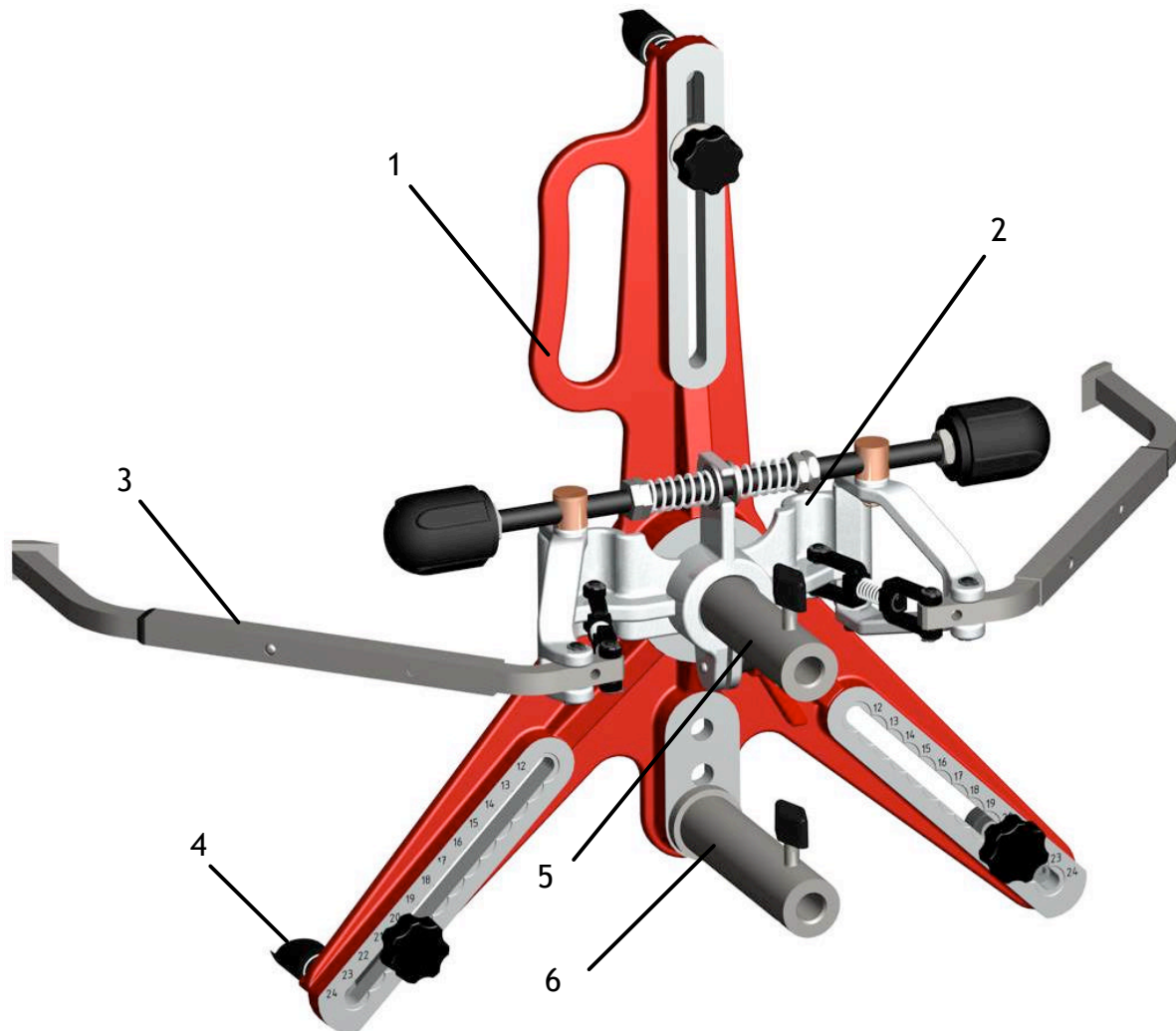

Main Components:

- 1: 1 x 3-Arm Star ProClamp PLUS
- 2: 1 x Grab Arm Assembly with Spindle (complete)
- 3: 2 x Telescopic Grab Arm
- 4: 3 x Foot
- 5: 1 x Spindle
- 6: 1 x Spindle for Spoiler adaptor (Option)

2. Description of Application

Adjustment of Rim Size

Preset the necessary rim diameter on the scale with the star grip screws (A).

With the spindle (B) preset the grab arms in such a manner that they fit between tyre and wheel arch/fender.



Note

Pay attention to the different types of rims!

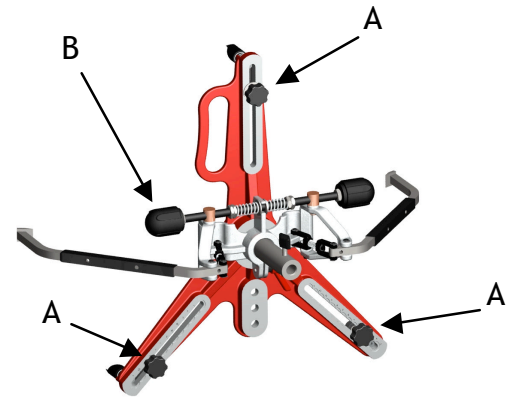

According to the rim design it may be necessary to use different feet (please see the optional accessories)

Attachment of the Wheel Alignment Clamp ProClamp PLUS to the Rim

First, the two bottom feet of the wheel alignment clamp are placed on the base of the rim.

Check if all three feet fit the base of the rim perfectly, if necessary correct the presetting with the star grip screw.



Positioning of the Wheel Alignment Clamp ProClamp PLUS

Push the wheel clamp against the rim and tighten it on the rim with the spindle (B).

If it fits perfectly and solidly, the measuring head can be mounted on the spindle.



Positioning of Spindle

Depending on the kind of vehicle you can add an additional spindle at the alignment clamp on three different places. This means that you can save the spoiler adaptor.



3. Optional Accessories

Extension Feet for Rims wider up to 26"

Clamping Kit (3 pieces) with long spring-loaded feet.

Part Number 912 008 087

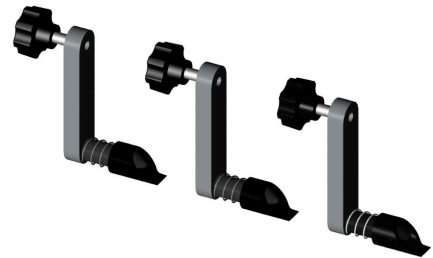

Special Feet for Utility Vehicles And Light Trucks

Plastic feet especially for rims with extra deep rim dishes.

Plastic Foot

Part Number 912 008 097 (12 pieces)

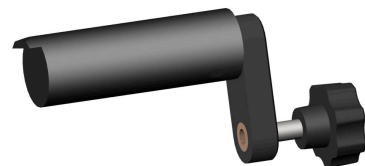

Note

In total 12 pieces are needed for the wheel alignment clamps !

4. Spare Parts List Wheel Alignment Clamp ProClamp PLUS

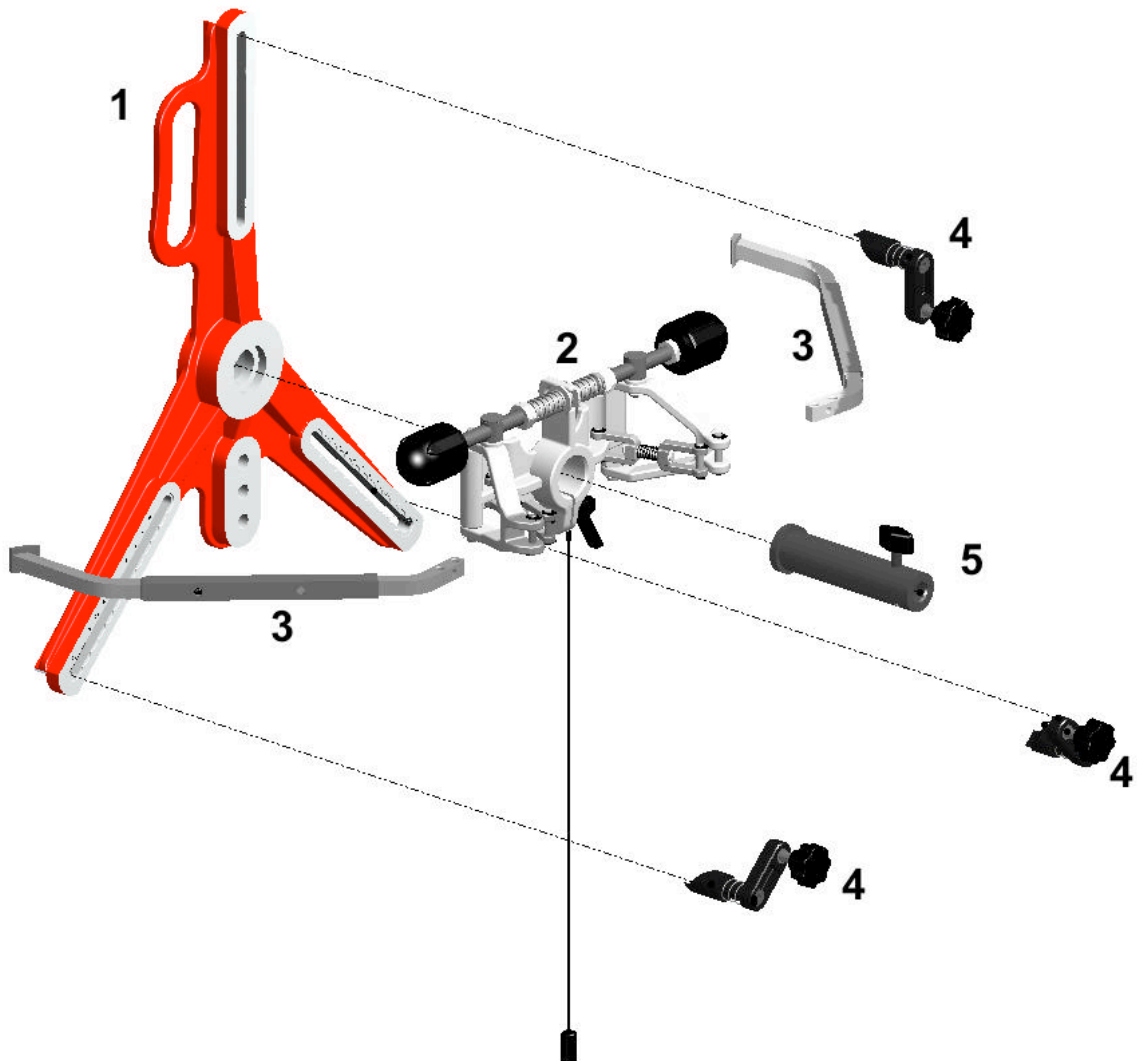

Note

For the Wheel Alignment Clamp ProClamp PLUS a repair kit for the Grab Arm Assembly is available.

Repair Kit Part Number 912 008 083



Spare Parts:

Pos.	Description	Part Number
1	3-Arm Star ProClamp PLUS	912e008 283
2	Grab Arm Assembly	912e008 277
3	Telescopic Grab Arm - 1 piece	912e008 158
4	Softline Foot - 1 piece	912e008 216
5	Spindle for Hunter DSP 250 - 1 piece	912e618 021
	Spindle for JBC neu V6/7 etc. - 1 piece	912e828 001
	Spindle for V501 / 901 JBC 2001 - 1 piece	912e829 001
	Spindle for Corghi - 1 piece	912e907 001
	Spindle for Cemb / Rav / Space - 1 piece	912e988 003
	Spindle for Beissbarth / Sicam - 1 piece	912e998 007

For further wheel alignment spindles, please contact Haweka Australia.

