

HL-52N

5TON WHEEL ALIGNMENT SCISSOR LIFT

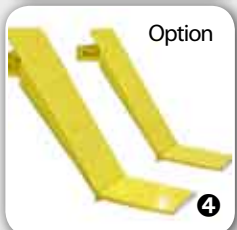

Option

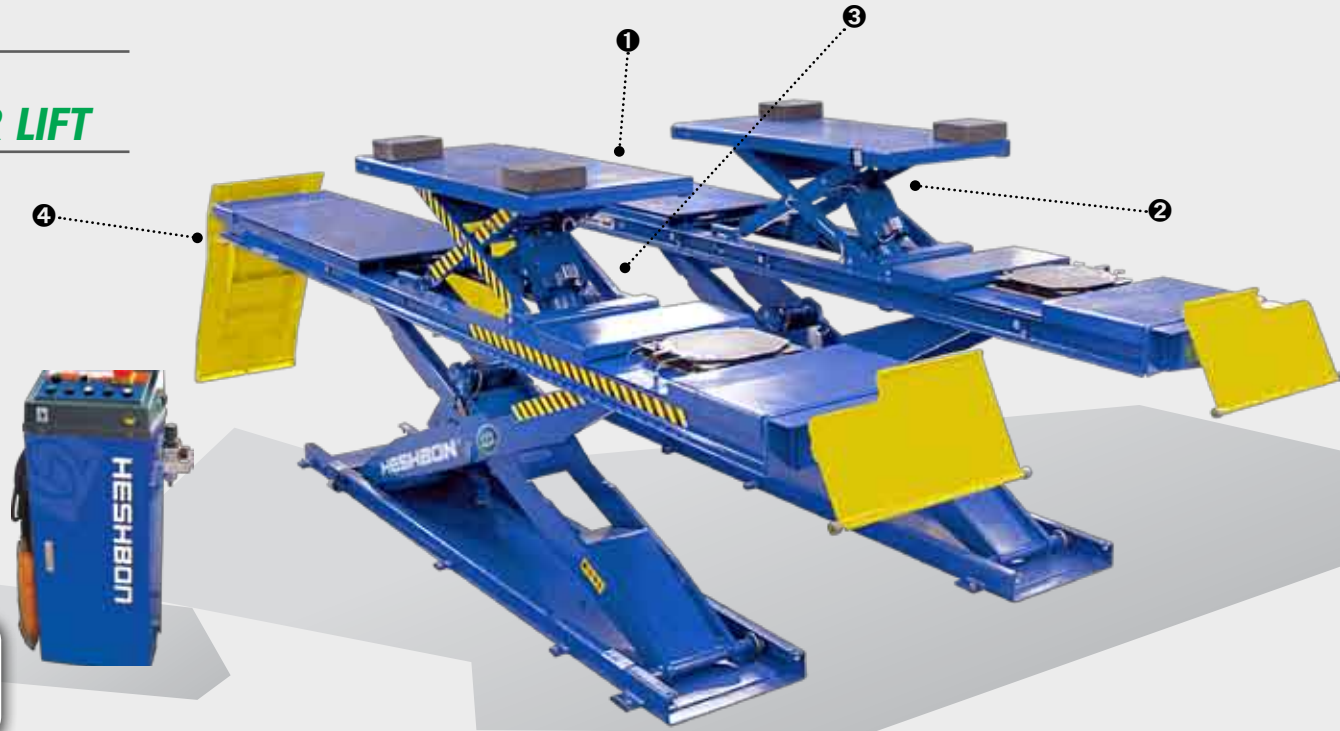

FEATURE

- Automatic air lock release device. • Locking position sensor.
- Hydraulic synchronization system without mechanical torsionbar.
- Descent alarm signal. • Floor-mounted or flush-mounted model.
- Electrical synchronization detecting system by photo-cell.
- Auxiliary lifts built into the platforms for wheel-free operation.
- Front turning plates recesses and rear slide plates for 4-wheel alignment operation.
- Pneumatic locks on rear slide plates. • Lighting set, 4 units. (option)
- Emergency ascent and descent systems. • Flush mount kit. (option)
- Two-step descent system gives full foot protection.
- Ramp extension for low chassis vehicle. (option)

SPECIFICATION

Model No.	HL-52N
Lifting Capacity (kg)	5,000 kg / 3,600 kg
Max.Lifting Height (mm)	Body : 2,007 / Jack : 438 mm
Dimension (mm)	6,715(L) X 2,126(W) X 265(H)
Power Supply & Motor	3ph : 3HP, 4P, 220/380V, 50/60Hz

LAY-OUT

