



Garage Equipment

PA-203BGT



Super automatic tyre-changer suitable for car and motorcycle wheels having rim size from 10" to 24" (max. diameter 1000 mm. / 39" max. wheel width 390 mm. / 15").

Equipped with a tubeless inflation tank that is mounted at the rear of the tyre machine and an automatic up/down tool head.

FEATURES

Tilt back tower - pneumatic operating arm locking - 22" outside turntable clamping - bead-breaker with double effect pneumatic cylinder - oversize chassis - extractable pedal unit.

STANDARD FEATURES

Rim clamping
Max. wheel diameter
Max. wheel width
Max. bead-loosener cylinder force
Operating pressure
Power supply
Motor power
Max. spindle torque
Inflating pressure limiting device max.

PA-203BGT

10" - 24"
1000 mm (39")
385 mm (15")
30800 N
10 bar (145 psi)
230 V 1 PH
0.8 Kw
1200 Nm
3.5 bar (50 psi)



Standard accessories include

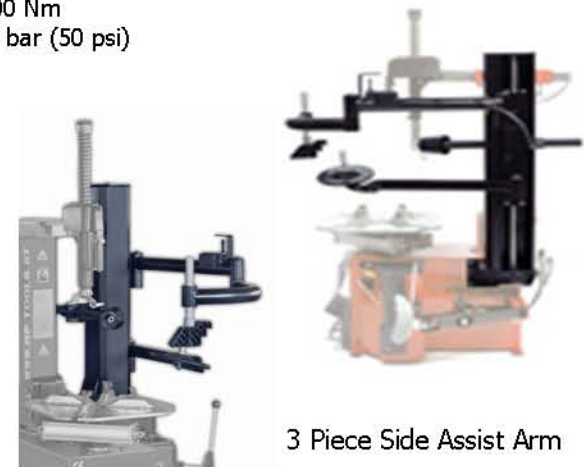

3 Piece Side Assist Arm

Contact your local authorised distributor:

AutoQuip
Kearm Business Park
Ballyoneen, Leamlara, Co. Cork.
021-4642889 / 086-1727569
info@autoquip.ie www.autoquip.ie

PHOENIX AUTOMOTIVE...the equipment professionals