

STD-6200T SERIES ELECTRO-HYDRAULIC TWO POST LIFT



SPECIFICATION STD-6232T/STD-6240T

Lifting capacity 3200kg/4000kg

Max. lifting height 1900mm

Min. height 98mm

Overall height 3750mm

Lifting time 45s

Lowering time 50s

Electric supply 220V/380V

Motor power 2.2kw/2.6kw

Weight 670kg/690kg

- Electro-hydraulic driven lift with chain lifting system
- Synchronization of cylinders independent from load distribution with mechanical leveling system
- Mechanical safeties with automatic engagement
- Choice of automatic or manual safety release
- Overload valves
- Lowering speed control
- 24VDC low tension control voltage
- Parachute valves
- Manual emergency pump optional
- Anti-crushing protections
- Crash-proof upper cross beam

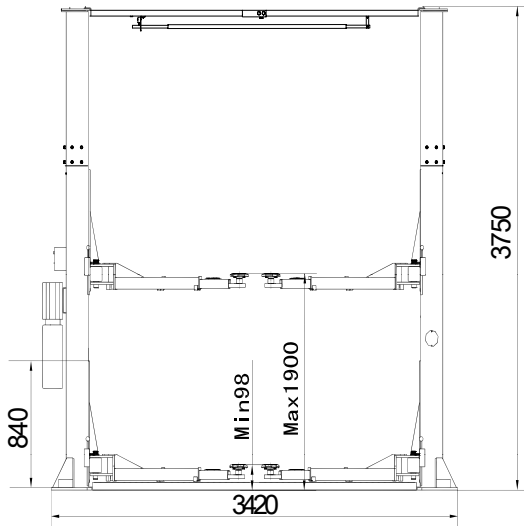

I I TYPE ARM

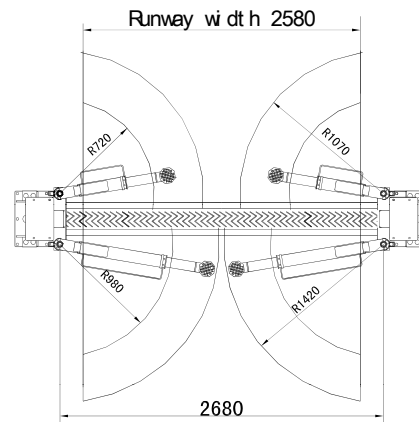

III TYPE ARM

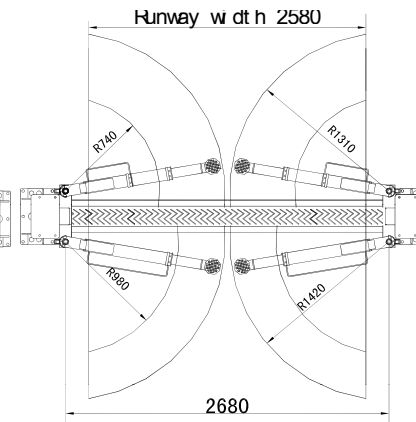

V TYPE ARM

